

# Electric Chain Hoists & Jib Cranes

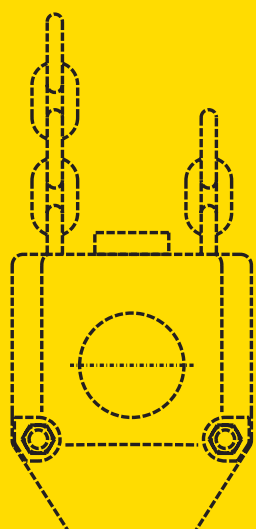

**CLF Series:**  
Reliable, safe, convenient, efficient  
and compact size

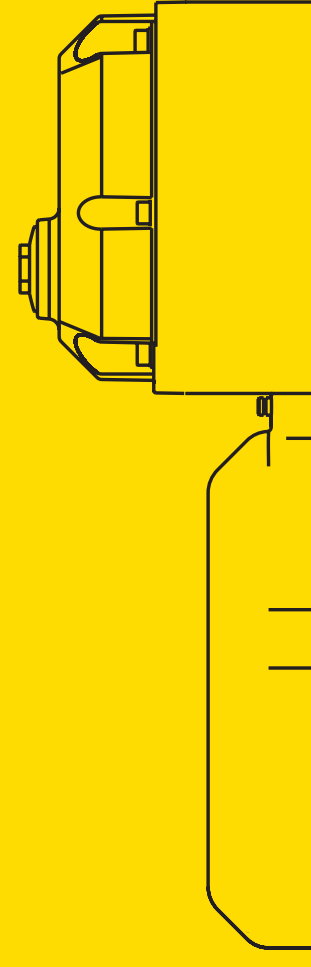
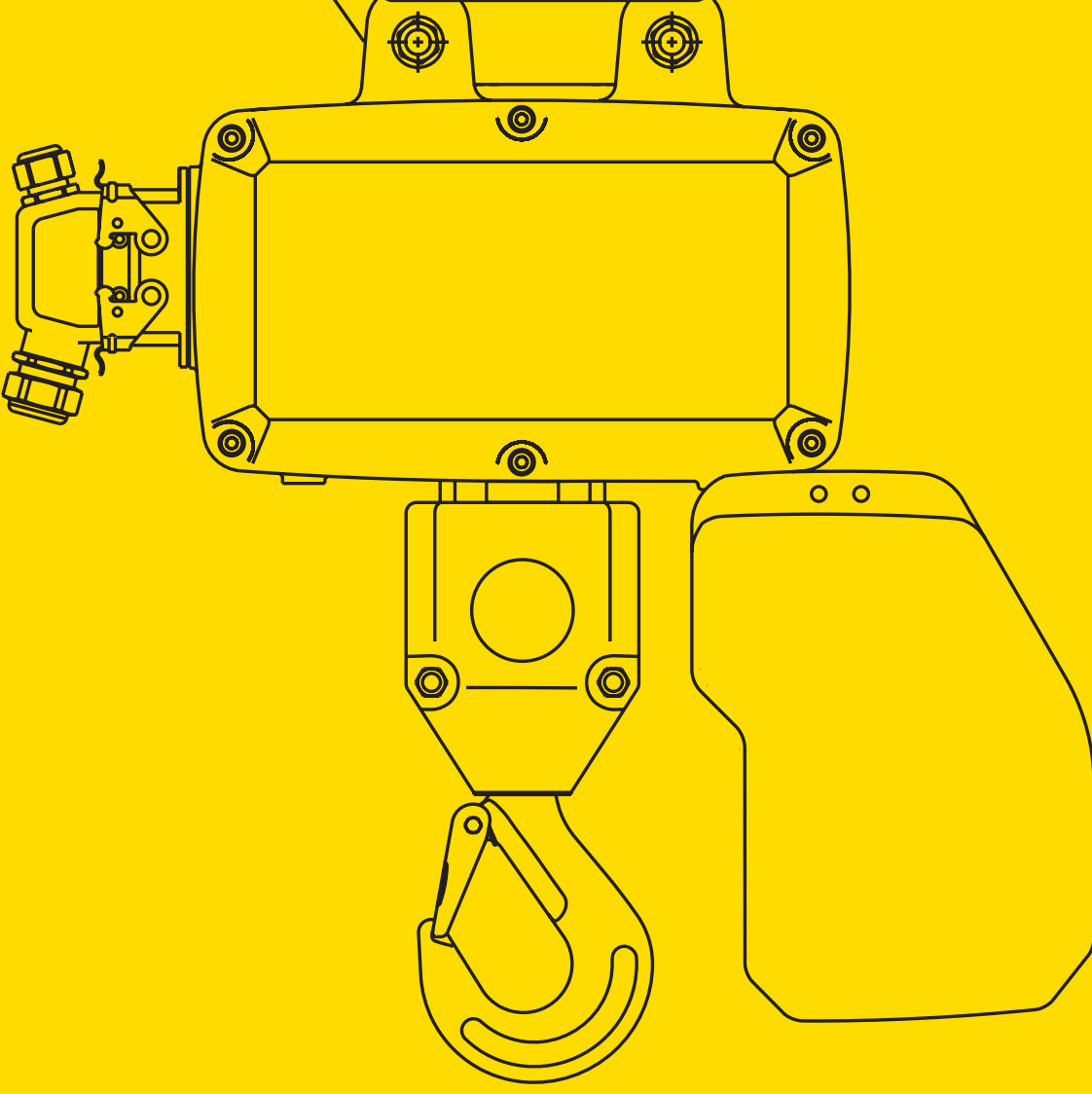
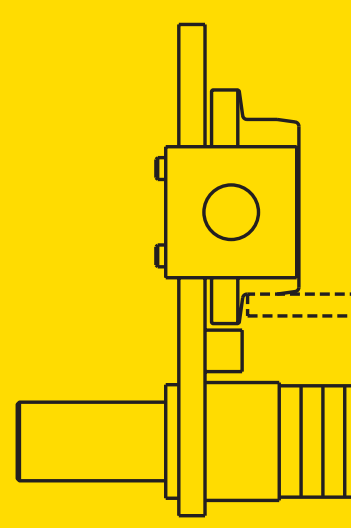
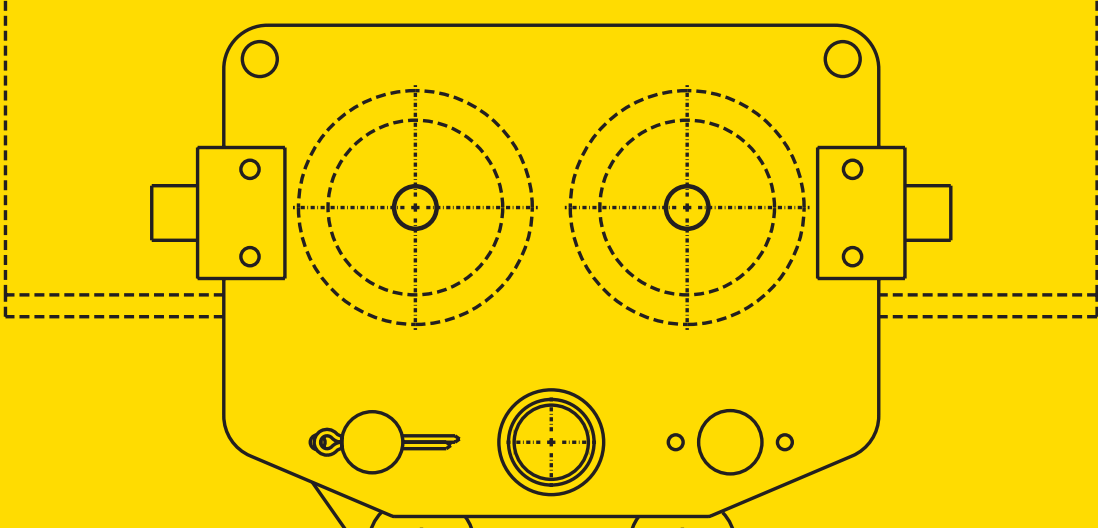

# Experience & Know-how by Podem

Podem chain hoists are durable lifting solution for a jib crane or for an overhead travelling crane

CLF hoist series provide many years of powerful performance and easy maintenance.

### Capacity range:

- From 125 to 2000 kg

### Advantages:

- Safety and high reliability
- High quality
- Compact size
- Excellent price/ performance ratio



### Technical Features

Hoist Features	CLF Series
Capacity	125 kg to 2000 kg
Lifting Speeds, Type	Double
Main Lifting Speeds, m/min	From 4 to 8 m/min
Electric Motor	Cylindrical 3-phase Motor
Electric Motor Fan	No
Operating Voltage	380-415 V / 50 Hz
Hoist Brake	85/95 V DC Electro-magnetic
Low Voltage Panel	Yes
Control Voltage	24 V (Optional 48 V, 240 V, etc)
Gear-box	Helical
FEM Group	1 Am, 2 m
Number of Starts per Hour	180 to 240
Duty Cycle	10+30% or 15+40%
IP Protection	IP55
Overload Limiter	Slipping Clutch
End Switch for Lifting	Optional*
Chain Type	Galvanized, Class DAT, EN818-7
Chain Size	2 Types
Chain Container	2 Types (Plastic)
Electric Trolley Speed, m/min	20/5, 20, 10
Push Trolley	Yes
Top Hook	Yes
Operating Temperature	-10 / +40 °C

\* On request

# CLF: Electric Chain Hoist Series of Podem

The series is available with eye bolt or top hook suspension, push or electric power travel trolleys

CLF series offers again very reliable product with excellent price/performance ratio.

Advantages:

- Simple and compact design
- Easy to adjust and minimum installation time
- High quality European components

## Housing

Aluminium die cast body, compact, light and rugged, motor and control panel made of shock resistant plastic.

## Hoist Motor

Three-phase asynchronous pole change motor with cylindrical rotor with class F insulation.

## Brake

Electro-mechanical disk brakes FD type allow quick and safe stop in any operating mode. Hoist brakes are with dust protection ring to improve durability and performance.

## Gearbox

Parallel shaft 3 stages gearbox provided with case hardened alloy steel helical gears to allow a very smooth transmission, vibration-free and low noise operations.

## Slipping Clutch

The safety clutch operating in oil bath is offered as a reliable overload safety and extends the service life of the gearbox and the motor. It must only be readjusted after 20,000 slipping occurrences.

## Low Voltage Control Panel

as standard. The integrated panel, built and wired according to EN 60204-32. The control board is protected inside the hoist aluminium body and sealed with a shock resistant plastic cover complete with rubber gasket to grant IP55 protection.

## Push Button Control

Ergonomic compact design, made of ABS copolymer with excellent mechanical intensity and electrical features. IP 66.

## Chain

Galvanized alloy steel chain, class DAT, highly resistant to fatigue and wear Conform to EN 818-7.

## Chain Container

Durable plastic containers available in two sizes.

## Suspension

Modular and outstanding flexibility. Easy replacement of eye bolt or swivel minimizes installation time. Easy switch from 1 to 2 falls operation

## Electric Trolley

Two metal structures and three type of motor reducers for all CLF range. Universal wheel profile and easy adjustable width for IPE, IPN, HEA or HEB beam types. Compact dimension allows running on curved track. Honed gears teeth reduce the noise level.

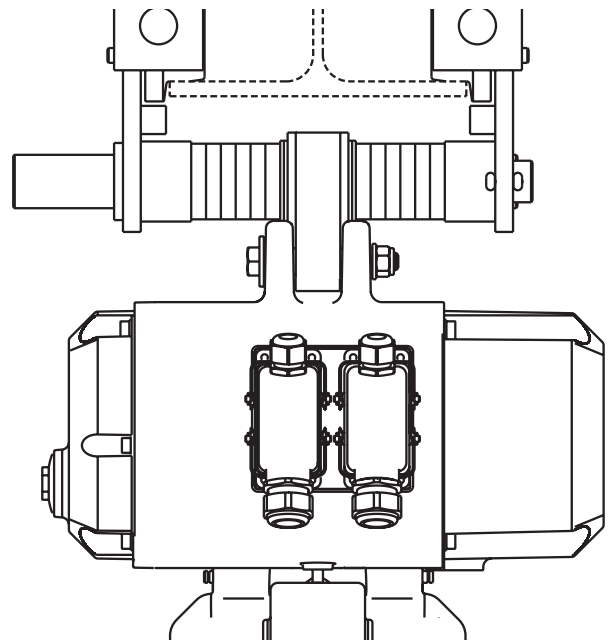
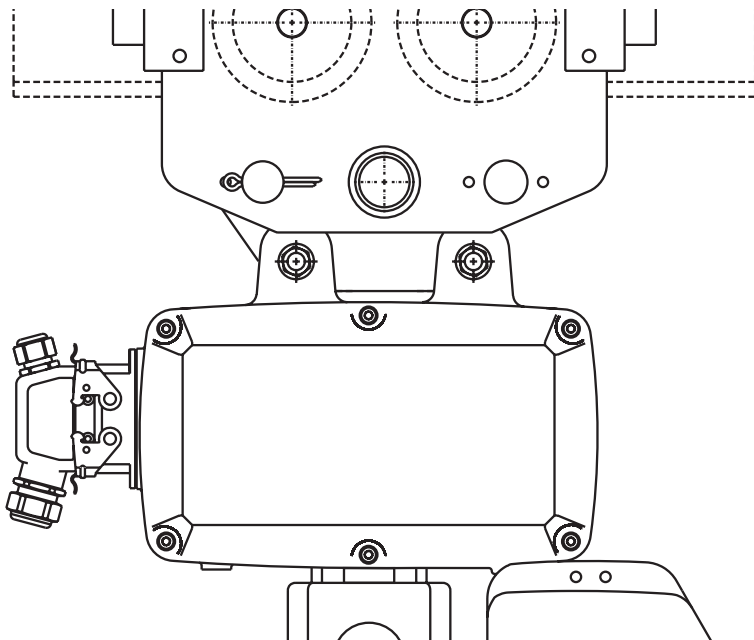

# Electric Chain Hoists

## CLF Series: Capacity from 125 to 2000 kg

### CLF-E Eye Bolt

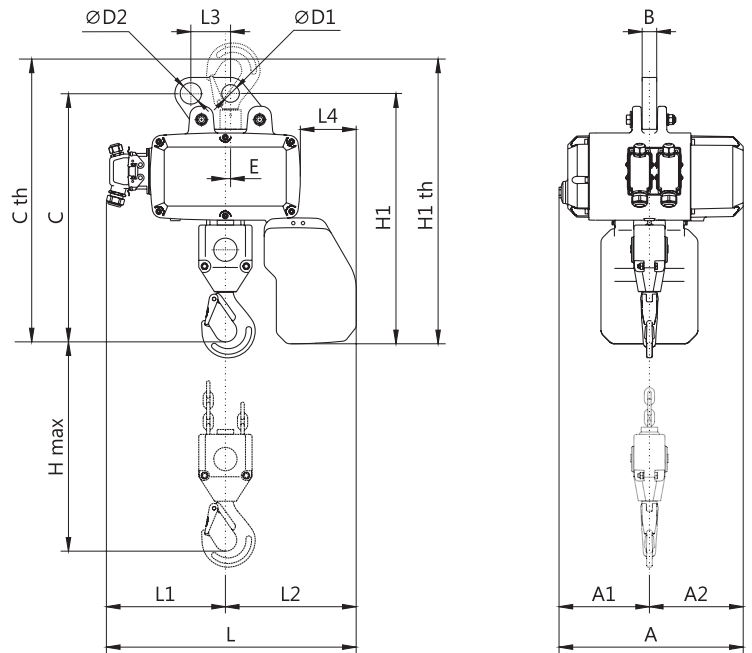

Top Hook

Type CLF-E (Eye Bolt)																								
Type	Capacity (kg)	FEM	Lifting Speed (m/min)	Lifting Motor (kW)	Ø Chain (mm)	Chain Falls	Min. Headroom		Dimensions													Weight H 3 m (kg)	Eyebolt, Hook Reaction (kg)	
							C	C th.	A	A1	A2	B	ØD1	ØD2	E	L	L1	L2	L3	L4	H1*			H1 th
0.1 CLF1...E	125	2m	8/2	0.09/0.36	5-15	1/1	394	443	332	169	163	20	30,5	38	-25	398	187	211	82	72	429	478	35	160
0.1 CLF2...E	125	3m	5/1.3	0.18/0.75	5-15	1/1	394	443	332	169	163	20	30,5	38	-25	398	187	211	82	72	429	478	35	160
0.1 CLF2...E	125	3m	8/2	0.18/0.75	5-15	1/1	394	443	332	169	163	20	30,5	38	-25	398	187	211	82	72	429	478	35	160
0.2 CLF1...E	250	2m	5/1.3	0.09/0.36	5-15	1/1	394	443	332	169	163	20	30,5	38	-25	398	187	211	82	72	429	478	35	285
0.2 CLF1...E	250	1Am	8/2	0.09/0.36	5-15	1/1	394	443	332	169	163	20	30,5	38	-25	398	187	211	82	72	429	478	35	285
0.2 CLF2...E	250	2m	5/1.3	0.18/0.75	5-15	1/1	394	443	332	169	163	20	30,5	38	-25	398	187	211	82	72	429	478	35	285
0.2 CLF2...E	250	2m	8/2	0.18/0.75	5-15	1/1	394	443	332	169	163	20	30,5	38	-25	398	187	211	82	72	429	478	35	285
0.5 CLF2...E	500	1Am	5/1.3	0.18/0.75	5-15	1/1	394	443	332	169	163	20	30,5	38	-25	398	187	211	82	72	429	478	35	535
0.5 CLF2...E	500	1Am	8/2	0.18/0.75	5-15	1/1	394	443	332	169	163	20	30,5	38	-25	398	187	211	82	72	429	478	35	535
1 CLF2...E	1000	1Am	4/1	0.18/0.75	5-15	2/1	422	471	332	169	163	20	30,5	38	1	398	212	186	82	72	429	478	36	1036
1 CLF3...E	1000	1Am	8/2	0.45/1.90	7-21	1/1	425	496	380	187	193	30	30,5	38	-25	472	235	237	82	115	517	588	55	1055
2 CLF3...E	2000	1Am	4/1	0.45/1.90	7-21	2/1	513	584	380	187	193	30	36,5	44	11	472	270	202	82	115	517	588	58	2058

\* Small chain collector up to 11 m chain

# Electric Chain Hoists

## CLF Series: Capacity from 125 to 2000 kg

### CLF-P Push Trolley

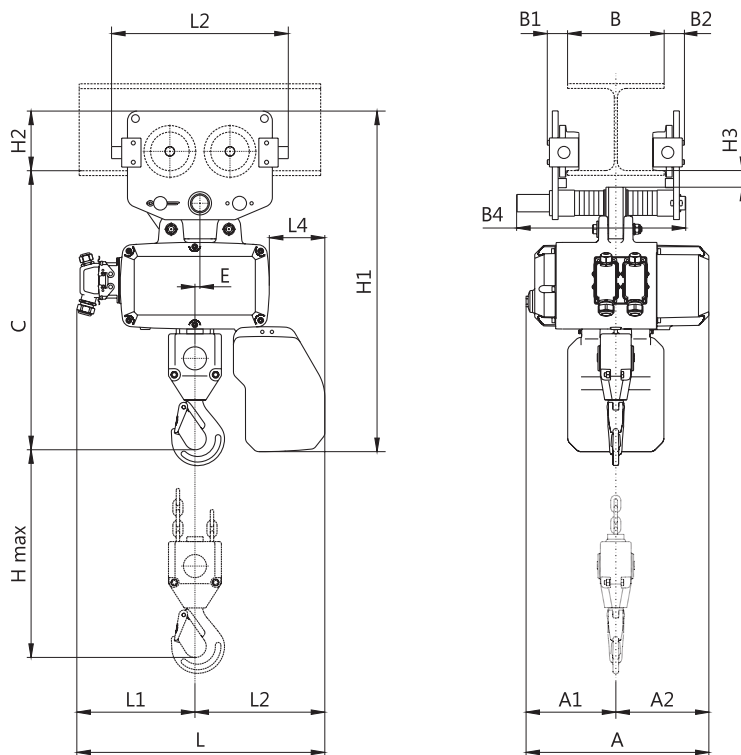
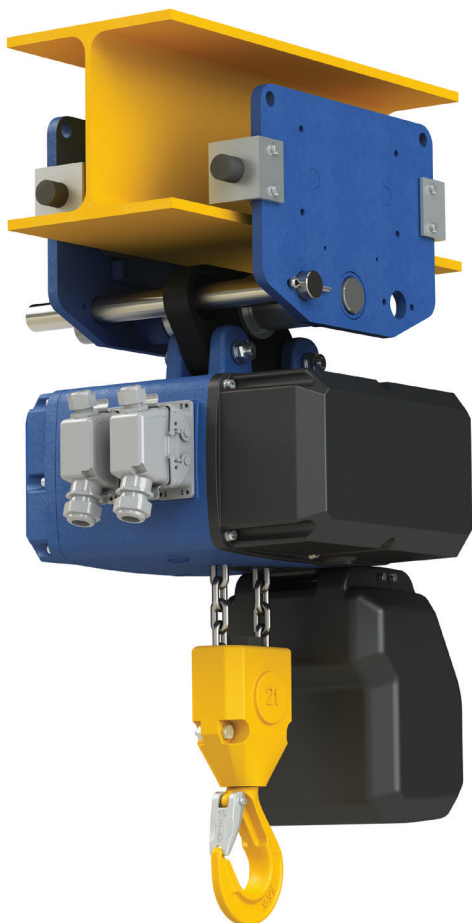

Type CLF-P (Push Trolley)

Type	Capacity (kg)	FEM	Lifting Speed (m/min)	Lifting Motor (kW)	Ø Chain (mm)	Chain Falls	Min. Headroom	Dimensions																Weight H 3 m (kg)	Max. Trolley Reaction (kg)	Max. Wheel Load (kg)		
								C	A	A1	A2	B	B1	B2	B3	B4	ØD	E	L	L1	L2	L3	L4				H1*	H2
0.1 CLF1...P	125	2m	8/2	0.09/0.36	5-15	1/1	469	332	169	163	50*...200*	31	31	23	329	60	-25	398	187	211	356	72	559	90	47	50	160	60
0.1 CLF2...P	125	3m	5/1.3	0.18/0.75	5-15	1/1	469	332	169	163	50*...200*	31	31	23	329	60	-25	398	187	211	356	72	559	90	47	50	160	60
0.1 CLF2...P	125	3m	8/2	0.18/0.75	5-15	1/1	469	332	169	163	50*...200*	31	31	23	329	60	-25	398	187	211	356	72	559	90	47	50	160	60
0.2 CLF1...P	250	2m	5/1.3	0.09/0.36	5-15	1/1	469	332	169	163	50*...200*	31	31	23	329	60	-25	398	187	211	356	72	559	90	47	50	285	107
0.2 CLF1...P	250	1Am	8/2	0.09/0.36	5-15	1/1	469	332	169	163	50*...200*	31	31	23	329	60	-25	398	187	211	356	72	559	90	47	50	285	107
0.2 CLF2...P	250	2m	5/1.3	0.18/0.75	5-15	1/1	469	332	169	163	50*...200*	31	31	23	329	60	-25	398	187	211	356	72	559	90	47	50	285	107
0.2 CLF2...P	250	2m	8/2	0.18/0.75	5-15	1/1	469	332	169	163	50*...200*	31	31	23	329	60	-25	398	187	211	356	72	559	90	47	50	285	107
0.5 CLF2...P	500	1Am	5/1.3	0.18/0.75	5-15	1/1	469	332	169	163	50*...200*	31	31	23	329	60	-25	398	187	211	356	72	559	90	47	50	535	201
0.5 CLF2...P	500	1Am	8/2	0.18/0.75	5-15	1/1	469	332	169	163	50*...200*	31	31	23	329	60	-25	398	187	211	356	72	559	90	47	50	535	201
1 CLF2...P	1000	1Am	4/1	0.18/0.75	5-15	2/1	497	332	169	163	50*...200*	31	31	23	329	60	1	398	212	186	356	72	587	90	47	51	1036	268
1 CLF3...P	1000	1Am	8/2	0.45/1.90	7-21	1/1	500	380	187	193	50*...200*	31	31	23	329	60	-25	472	235	237	356	115	590	90	47	70	1055	394
2 CLF3...P	2000	1Am	4/1	0.45/1.90	7-21	2/1	581	380	187	193	64*...200*	42	42	29,5	348	80	11	472	270	202	366	115	704	124	34,5	84	2058	609

\* Small chain collector up to 11 m chain

# CLF-N

Electric Trolley

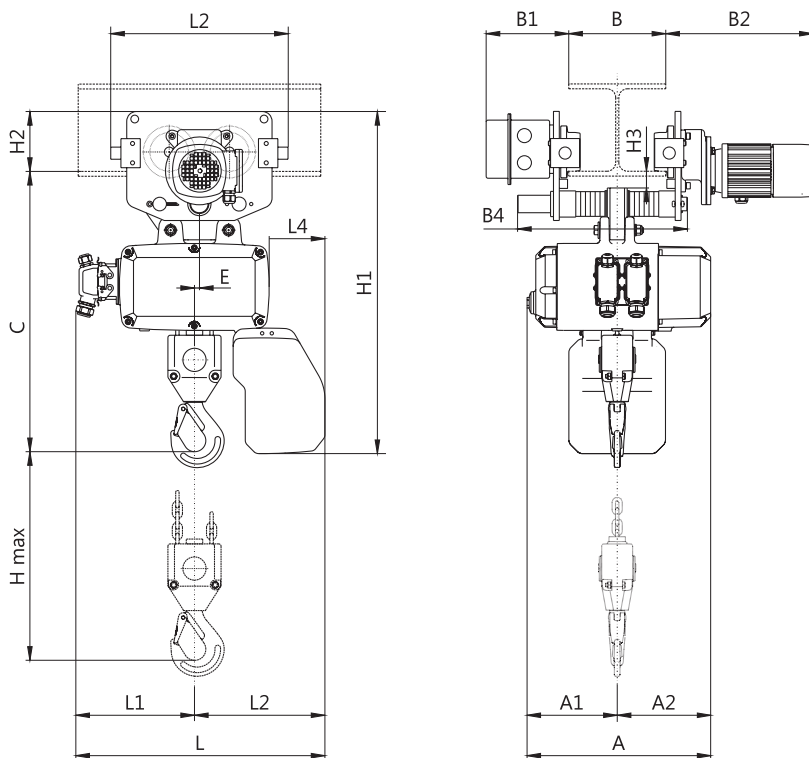

Type CLF-N (Electrical Trolley)																												
Type	Capacity (kg)	FEM	Lifting Speed (m/min)	Lifting Motor (kW)	Ø Chain (mm)	Chain Falls	Min. Headroom	Dimensions																Weight H 3 m (kg)	Max. Trolley Reaction (kg)	Max. Wheel Load (kg)		
								C	A	A1	A2	B*	B1	B2	B3	B4	ØD	E	L	L1	L2	L3	L4				H1*	H2
0.1 CLF1...N	125	2m	8/2	0.09/0.36	5-15	1/1	469	332	169	163	50-200	164	298	23	329	60	-25	398	187	211	356	72	559	90	47	63	160	63
0.1 CLF2...N	125	3m	5/1.3	0.18/0.75	5-15	1/1	469	332	169	163	50-200	164	298	23	329	60	-25	398	187	211	356	72	559	90	47	63	160	63
0.1 CLF2...N	125	3m	8/2	0.18/0.75	5-15	1/1	469	332	169	163	50-200	164	298	23	329	60	-25	398	187	211	356	72	559	90	47	63	160	63
0.2 CLF1...N	250	2m	5/1.3	0.09/0.36	5-15	1/1	469	332	169	163	50-200	164	298	23	329	60	-25	398	187	211	356	72	559	90	47	63	285	110
0.2 CLF1...N	250	1Am	8/2	0.09/0.36	5-15	1/1	469	332	169	163	50-200	164	298	23	329	60	-25	398	187	211	356	72	559	90	47	63	285	110
0.2 CLF2...N	250	2m	5/1.3	0.18/0.75	5-15	1/1	469	332	169	163	50-200	164	298	23	329	60	-25	398	187	211	356	72	559	90	47	63	285	110
0.2 CLF2...N	250	2m	8/2	0.18/0.75	5-15	1/1	469	332	169	163	50-200	164	298	23	329	60	-25	398	187	211	356	72	559	90	47	63	285	110
0.5 CLF2...N	500	1Am	5/1.3	0.18/0.75	5-15	1/1	469	332	169	163	50-200	164	298	23	329	60	-25	398	187	211	356	72	559	90	47	63	535	204
0.5 CLF2...N	500	1Am	8/2	0.18/0.75	5-15	1/1	469	332	169	163	50-200	164	298	23	329	60	-25	398	187	211	356	72	559	90	47	63	535	204
1 CLF2...N	1000	1Am	4/1	0.18/0.75	5-15	2/1	497	332	169	163	50-200	164	298	23	329	60	1	398	212	186	356	72	587	90	47	64	1036	271
1 CLF3...N	1000	1Am	8/2	0.45/1.90	7-21	1/1	500	380	187	193	50-200	164	298	23	329	60	-25	472	235	237	356	115	590	90	47	83	1055	397
2 CLF3...N	2000	1Am	4/1	0.45/1.90	7-21	2/1	581	380	187	193	64-200	171	303	29,5	348	80	11	472	270	202	366	115	704	124	34,5	97	2058	613

\* Small chain collector up to 11 m chain

# Electric Chain Hoists

## Technical Details

### Chain Hoist CL Series Code Breakdown

Example	1	CL	F1	H6	V4	1/1	M	N	52	10
Capacity (t)										
Series										
Hoist Size										
Standard Height of Lift H (m)										
Lifting Speed V (m/min)										
Falls of Chain										
Speed Type for Lifting Speed										
Hoist Type										
Electro Equipment According to Podem Codding										
Electric Trolley Speed (m/min)										

### Trolley Models

Monorail Trolley Range								Optional
Hoist Type	Capacity (kg)	Speed	Trolley Model	Beam Flange b (mm)	Motor	Power (kW)	RPM (1/min)	Beam Flange b (mm)
P	125-1000	-	KC 0601 PC	50-200	-	-	-	50-300
P	1500-2000	-	KC 0801 PC	64-200	-	-	-	64-300
E	125-1000	20/5	KM 0601 V20/5	50-200	T63B-2/8 BR 42	0.15/0.03	2800/650	50-300
E	1500-2000	20/5	KM 0801 V20/5	64-200	T63B-2/8 BR 42	0.15/0.03	2800/650	64-300
E	125-1000	20	KM 0601 V20	50-200	T63A-2 BR 42	0,18	2690	50-300
E	1500-2000	20	KM 0801 V20	64-200	T63A-2 BR 42	0,18	2690	64-300
E	125-1000	10	KM 0601 V10	50-200	T63B-4 BR 42	0,18	1360	50-300
E	1500-2000	10	KM 0801 V10	64-200	T63B-4 BR 42	0,18	1360	64-300

\* Different sizes available on request

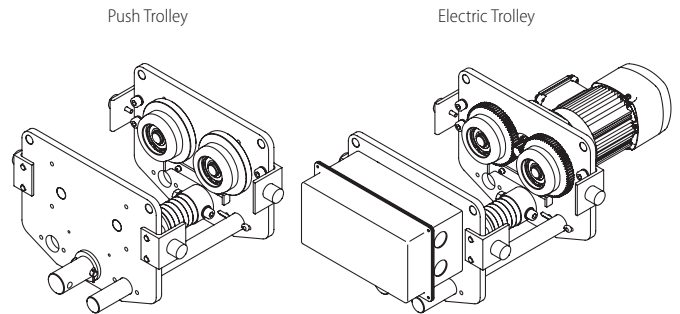

### Hook Models

Pull of Chain 1/1								
Capacity (kg)	a	b	c	d	e	f	g	s
125	79	84	28	57	25	39	88	19
200	79	84	28	57	25	39	88	19
250	79	84	28	57	25	39	88	19
500	79	84	28	57	25	39	88	19
1000	79	84	28	57	25	39	88	19
Pull of Chain 2/1								
Capacity (kg)	a1	b1	c1	d1	e1	f1	g1	s
1000	107	84	28	80	25	39	88	19
2000	148	103	33	110	34	44	111	24

CLF Hook Block 1/1

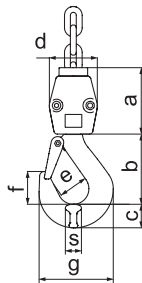

CLF Hook Block 2/1

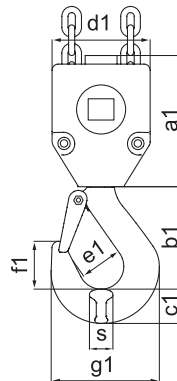

### Chain

Chain 818-7, DAT					
Nominal Diameter (mm)	Pitch (mm)	5 Link Pitch (mm)		Tolerance Limit (d)	Weight (kg/m)
		Standard	Limit		
5	15	75	77,5	4,5	0,54
7	21	105	108,5	6,3	1,1

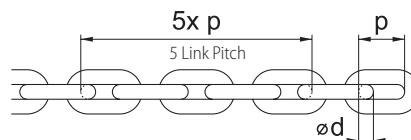



# Standard Jib Cranes

More Productivity, More Safety, More Efficiency



The jib crane is the most practical and economical solution to make independent a workplace otherwise requiring the use of a bridge crane or forklift. In addition, a jib crane solves the issue of load handling in tight spaces where different lifting equipment would not be able to operate.

## Advantages

- Made in European Union
- A large product range of standard jib cranes
- High quality standard

Type	Column or Wall-mounted Jib Cranes				
	C / M	CT / MT	C2T/M2T	CTE/MTE	C2TE/M2TE
Capacity Min (kg)	125	125	250	250	250
Capacity Max (kg)	1000	2000	2000	2000	2000
Arm's length Max (m)*	8	8	8	8	8
Beam type	profile	I-beam	I-beam	I-beam	I-beam
Rotation Max	270	270	270	270/200	270/200
Rotation type	manual	manual	manual	electric	electric
Arm braced connection	over	under	over	under	over

\* Related to the capacity

# Standard Jib Cranes

## Product Range

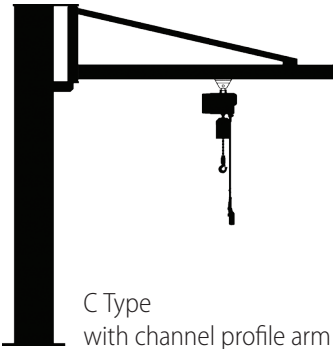

### C Type

Column-mounted

### M Type

Wall-mounted

- Channel Profile Arm
- Push Trolley

The arm, manufactured with a special press-formed channel profile, stable and light, ensures the best swinging sensitivity and sliding of the trolley. The rigid structure of the column ensures the stability of the trolley during all lifting stages. Available with manual push trolley. All cranes are supplied complete with power supply line and junction box.

- Arm's length from 2 to 8 m
- Rotation 270°
- Capacity from 125 to 1000 kg

		Outreach (m)							
		2	3	4	5	6	7	8	
Capacity (kg)	125								
	250								
	500								
	1000								
	2000								

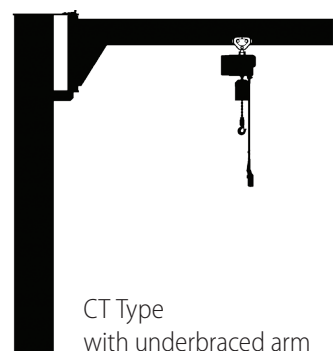

### CT Type

Column-mounted

### MT Type

Wall-mounted

- I-beam Arm
- Electric or Push Trolley

This is an optimal solution where the maximum exploitation of available height is required with further increase of hook travel. The rigid structure of the column ensures the stability of the trolley in all positions of the jib. The bearings mounted on the rotation unit allow a smooth rotation. Available with mechanical, electric or manual push trolley. All cranes are supplied complete with power supply line and junction box.

- Arm's length from 2 to 8 m
- Rotation 270°
- Capacity from 125 to 2000 kg

		Outreach (m)							
		2	3	4	5	6	7	8	
Capacity (kg)	125								
	250								
	500								
	1000								
	2000								



### C2T Type

Column-mounted

### M2T Type

Wall-mounted

- I-beam Arm
- Electric or Push Trolley

The column-mounted cranes with tie beam arm ensure ease of swinging and trolley stability even in case of significant capacity and long jibs. The rotation unit is always mounted on bearings. Available with mechanical, electric or manual push trolley. All cranes are supplied complete with power supply line and junction box.

- Arm's length from 3 to 8 m
- Rotation 270°
- Capacity from 250 to 1000 kg

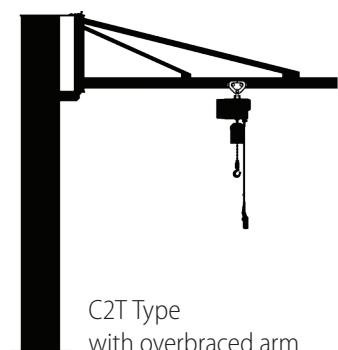

C2T Type with overbraced arm

		Outreach (m)						
		2	3	4	5	6	7	8
Capacity (kg)	125							
	250							
	500							
	1000							
	2000							

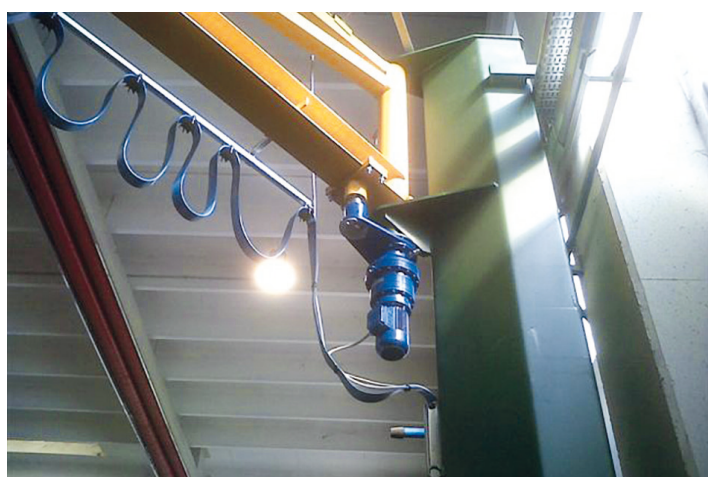

Electric rotation:

### CTE Type

Column-mounted

### MTE Type

Wall-mounted

- Electric Rotation: CTE=270°, MTE=200°

The rotation of the jib occurs through a system of gearmotorjoint coupled directly to the pivot pin and it is regulated by an inverter; it is equipped with an epicyclical reduction and driven by an electric self-braking motor with a soft start. The push-button is supplied hanging from the hoist or sliding independently, as needed.

		Outreach (m)						
		2	3	4	5	6	7	8
Capacity (kg)	125							
	250							
	500							
	1000							
	2000							

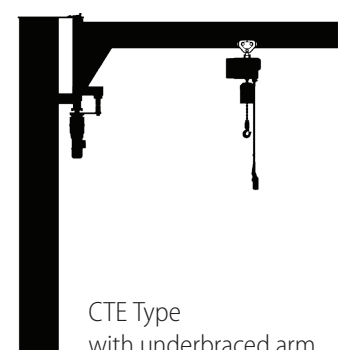

CTE Type with underbraced arm

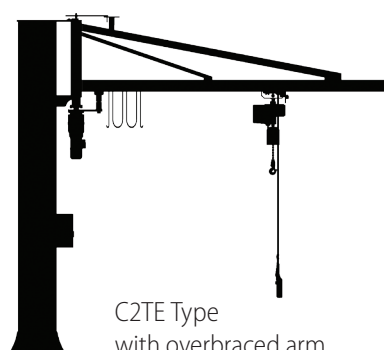

C2TE Type with overbraced arm

Option with overbraced arm:

### C2TE Type

Column-mounted

### M2TE Type

Wall-mounted

- Electric Rotation: C2TE=270°, M2TE=200°

		Outreach (m)						
		2	3	4	5	6	7	8
Capacity (kg)	125							
	250							
	500							
	1000							
	2000							

# Column & Wall-mounted Jib Cranes

## Safety Distances

### Column-mounted Jib Cranes

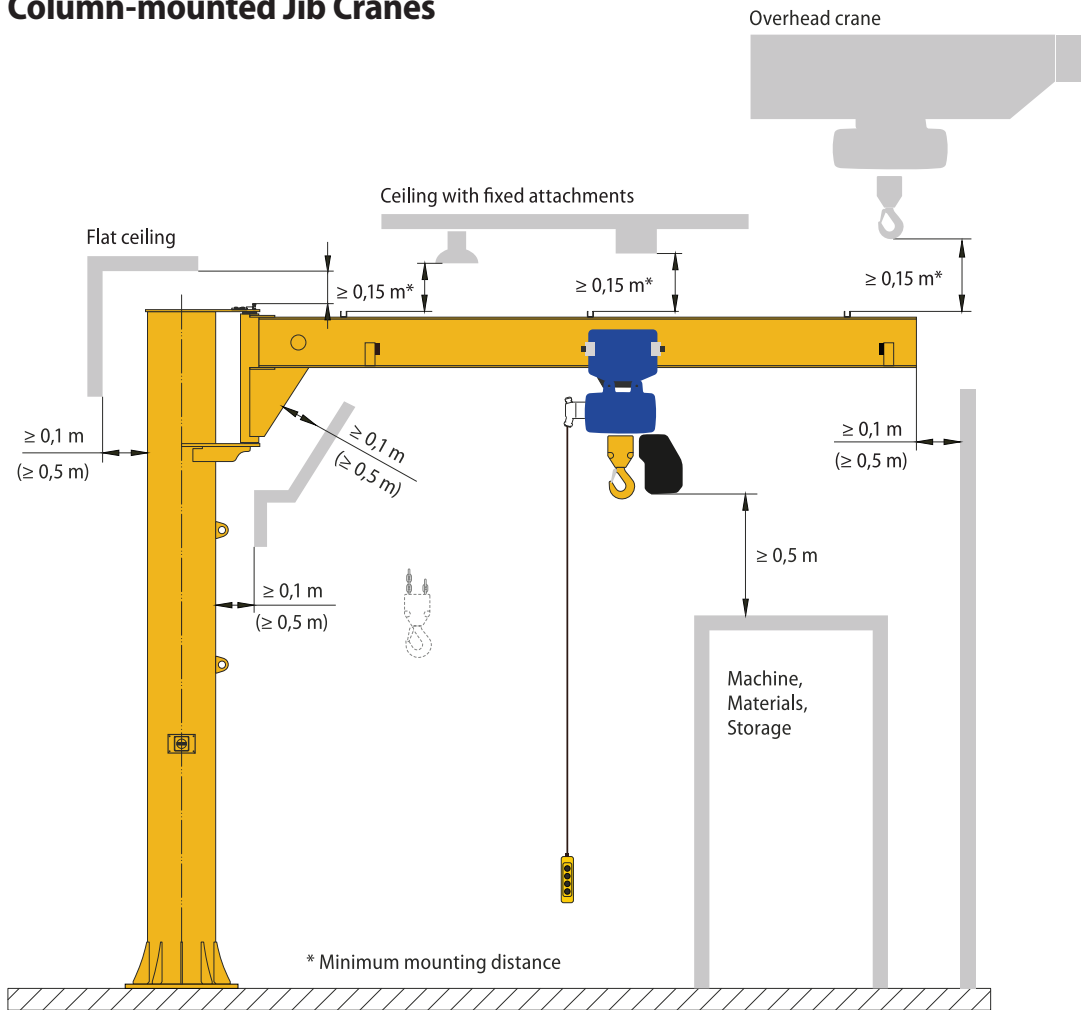

### Wall-mounted Jib Cranes

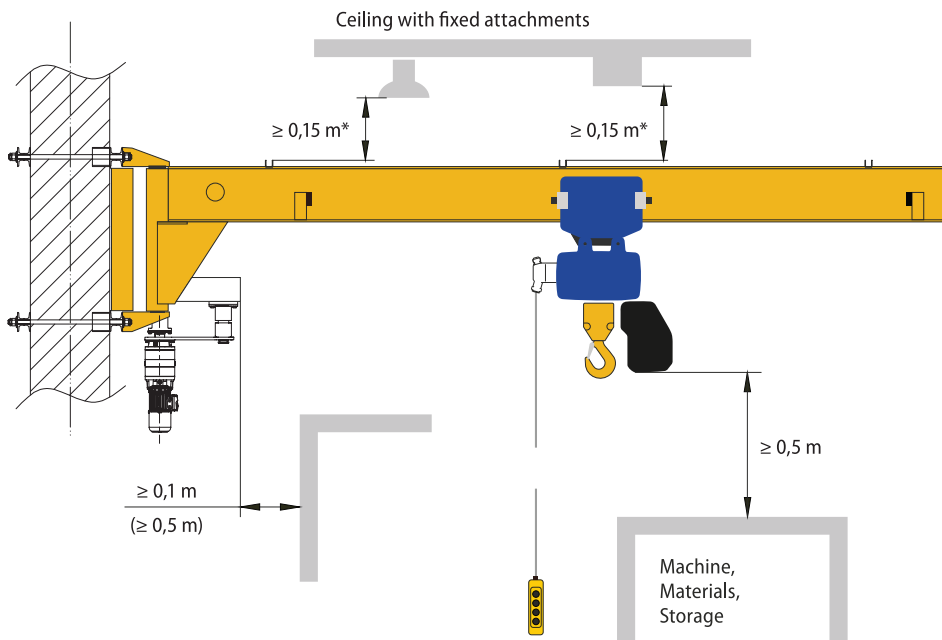

All dimensions apply to safety distances outside (dimensions in [ ] within) the working- and operating area. Usually, the working- and operating area is 2.5 m from the floor. The safety distances are only applicable for power-operated crane-parts.

# Column & Wall-mounted Jib Cranes

## Mounting, Fastening

### Column-mounted Jib Cranes

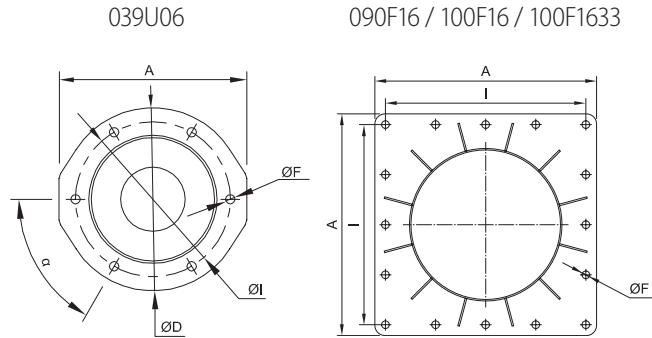
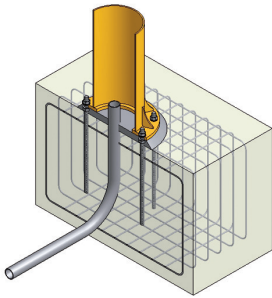

Round or square solution on existing concrete floor.  
The base plates for fixing to the floor with chemical anchor bolts.  
For the reliability of the anchoring system the jib crane:  
– Each bolt will be subject to a tensile strength of ~ 31.25 kN

- Concrete strength not less than C25 (i.e. 25 N/mm<sup>2</sup>)
- Floor minimum thickness 180 mm (M16) and 220 mm (M20)
- Floor with relevant metal reinforcement to withstand the aforementioned strength around the bolts.

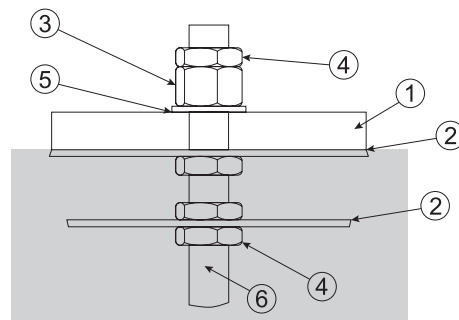
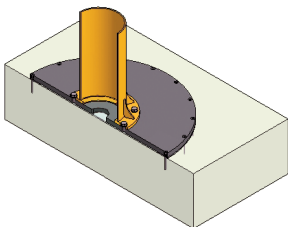

1. Base plate of the crane
2. Sheet mask
3. High nut
4. Thin nut
5. Spacer
6. Anchoring bolt

The dimensioning of the jib crane fixing plinth must be done by a specialized technician and enabled according to the specific loads of the cranes to be installed, which are indicated on the technical tables and the real characteristics of the ground where it will be built.

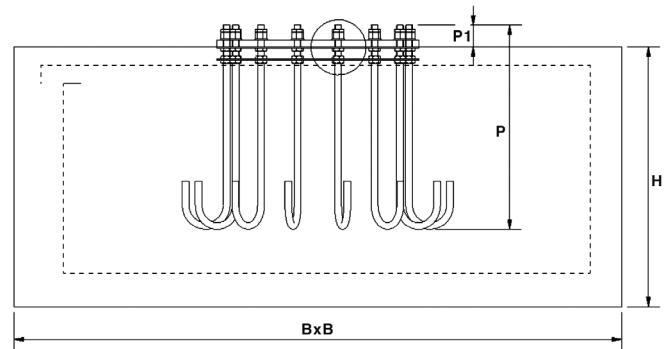

### Wall-mounted Jib Cranes

The wall-mounted cranes are anchored to the pillar by means of tie rods and counter supports. Upon request, Podem produces brackets for anchoring on the edge of the pillar or custom counter supports.

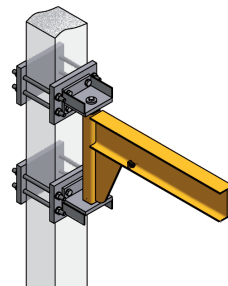

# Other Lifting Solutions:

## Light Crane Systems

### Light Crane Systems

Loads up to 2000 kg  
Bridge span up to 10 m

#### Floor-mounted

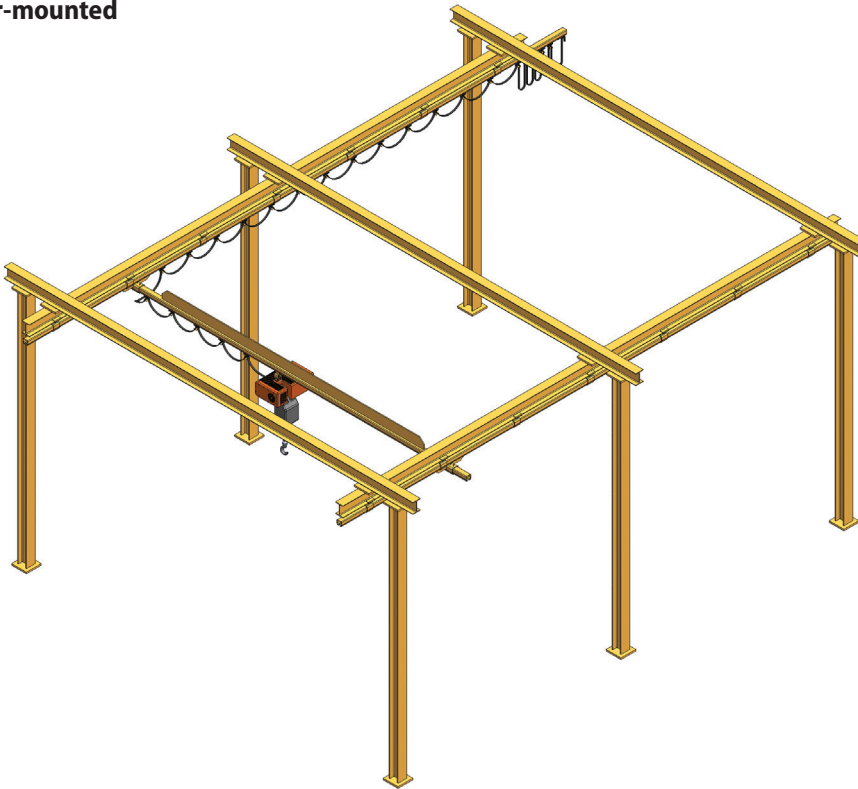

Podem provides an ergonomic and cost-effective light crane system when there is a height and space restriction. Modular design allows extendibility and relocability. The robust design of our components and the high standard of manufacturing guarantees long life with the minimum of maintenance.

Floor-mounted cranes are particularly useful when the roof cannot support an overhead Crane.

Ceiling-mounted cranes are useful where the floor space is limited. Since the cranes are directly mounted on the ceiling and no supporting columns are necessary the working floors are kept clear for other operations.



#### Ceiling-mounted

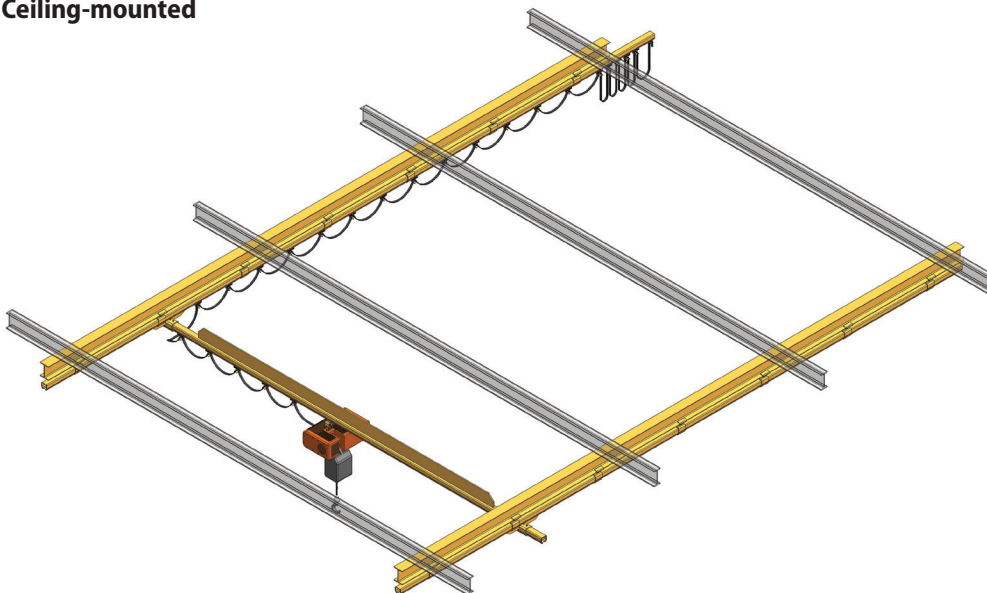

# Other Lifting Solutions:

## Movable Portal Cranes

### Movable Portal Cranes

Capacity: 500 – 5000 kg

Portal span: 3000 – 8000 mm

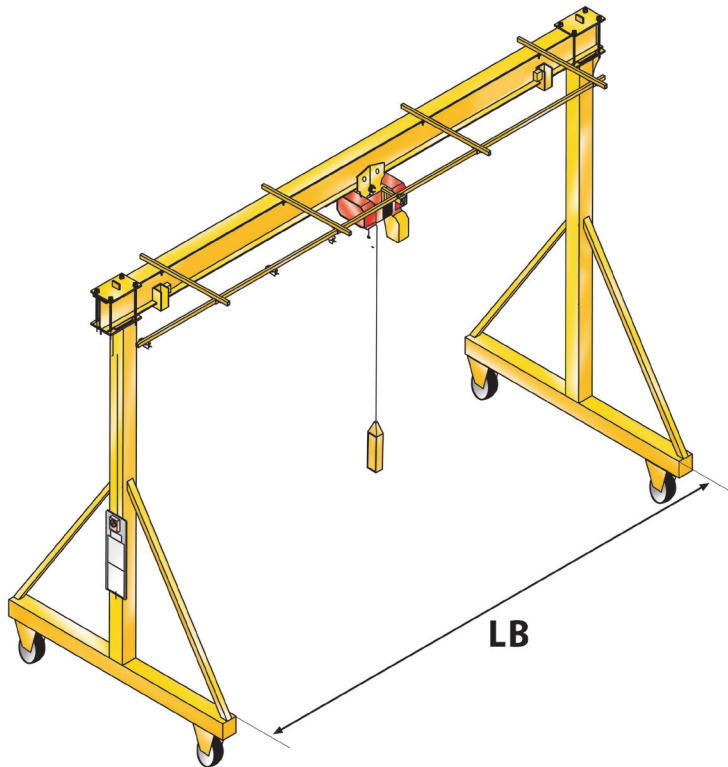

Lifting and material handling jobs are not always predictable. A movable portal crane is the perfect choice when:

- There is not enough room for a mobile crane or a forklift
- The overhead crane is not always available
- The equipment is too expensive for occasional use

The portal crane can be moved rapidly for use in any location and put into operation immediately. It could be stationary or movable with steerable / stoppable wheels

The construction could be steel or aluminium.

Currently the aluminium gantry cranes are preferable. They are easy movable under load, highly mobile, flexible, light weight, height and length adjustable, suitable for several work sites and applications.

#### Specification:

- Gantry crane movable under load, suitable for flat, plain and even floors without obstacles
- Wheels with heavy-duty polyurethane lining
- All the wheels with brake to avoid the crane can roll or rotate
- Height adjustable with steps by 50 mm to adapt the crane to several lifting applications or to different floor levels
- Adjustment feet with steps by 40 mm for not even floors
- Adjustable span between the lateral stands
- Aluminium plain manual trolley with rubber bumpers, suitable for manual or electric chain hoist
- Foldable lateral stands for easy transport and storage
- Very light weight

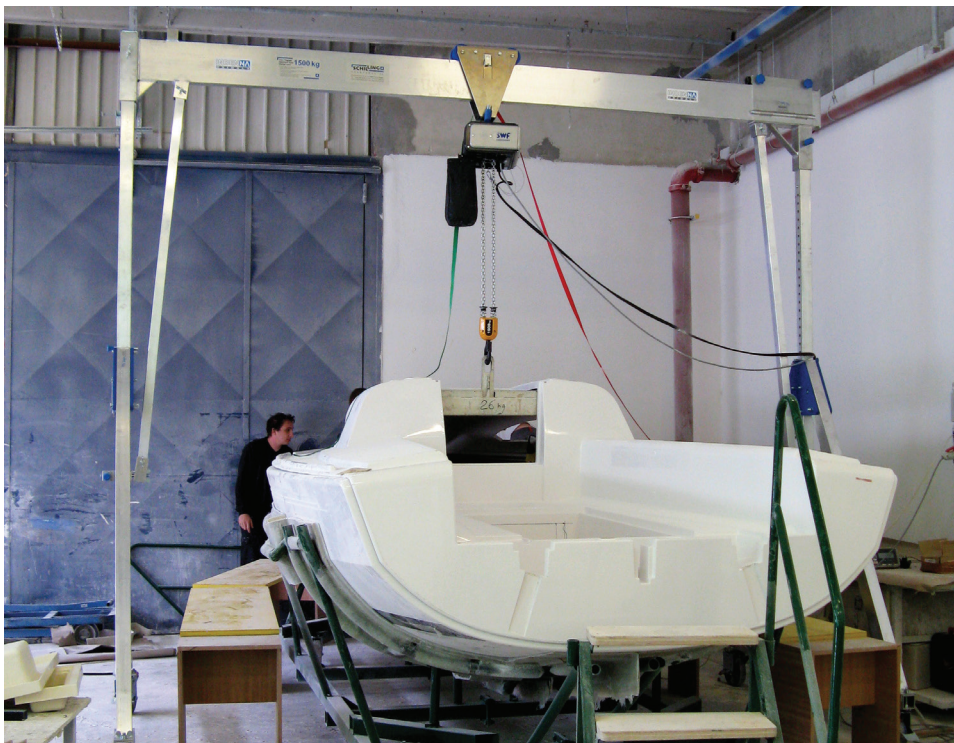

**Electric Chain Hoists  
& Jib Cranes**

April 2020



**Podemcrane AD**  
1 General Nikolov St.  
5300 Gabrovo  
Bulgaria

International Market  
+359 66 801 375  
sales@podem.bg  
podem.bg

Regional Market  
+359 66 816 277  
sales@podemcrane.com  
podemcrane.com